

Development Board EPC9148 Quick Start Guide

48 V Three-level Synchronous Buck Converter, Using EPC2053

Revision 1.0



DESCRIPTION

The EPC9148 demonstration board is a 60 V maximum input voltage, 12.5 A maximum output current, 19 V output voltage, ultra-thin three-level synchronous buck converter with only 3.5 mm component height. It features the 40 V EPC2055 and the 100 V EPC2053 and EPC2038 GaN FETs. The purpose of this demonstrate board is to simplify the evaluation of GaN FET-based multi-level synchronous buck converter. For more information on the GaN-based multilevel topology please see How2AppNote 015: *How to Design an Ultra-thin, Highly Efficient, Multilevel DC-to-DC Converter*.

A simplified block diagram of the EPC9148 development board is shown in Figure 1. It contains one EPC2053 for Q1, three EPC2055 for Q2-Q4 in the power stage, and three EPC2038 GaN FETs for the synchronous bootstrap gate drive circuits with the uPI Semiconductor uP1966A gate drivers. The board also includes on-board housekeeping power supply, digital controller, current and voltage sensing, and output filter. Kelvin sensing test points of the input and output voltages are provided for accurate efficiency measurement.

For more information on EPC2055, EPC2053 and EPC2038, please refer to the datasheet available from EPC at epc-co.com. The datasheet should be read in conjunction with this quick start guide.

Table 1: Performance Summary (T_A = 25°C) EPC9148

Symbol	Parameter	Conditions	Min	Typ	Max	Units
V _{IN}	Input Voltage Range ⁽¹⁾		44	48	60	V
V _{OUT}	Output Voltage ⁽²⁾			19		V
I _{OUT}	Output Current ⁽³⁾				12.5	A
f _{SW}	Switching frequency			400		kHz
	Peak efficiency	48 V _{IN} , 8-10 A I _{OUT} , 400 LFM		97.9		%
	Full load efficiency	48 V _{IN} , 12.5 A I _{OUT} , 400 LFM		97.8		%

- (1) Maximum input voltage depends on inductive loading, maximum drain-source voltage must be kept under 32 V and 80 V for EPC2055 and EPC2053 respectively. Minimum input voltage depends on the output voltage. When the output voltage is lower, it can operate from a lower supply voltage.
- (2) Output voltage can be programmed to be 5-20 V, contact EPC for more info.
- (3) Maximum current depends on die temperature – actual maximum current is affected by switching frequency, voltage, thermal cooling, as well as the saturation current of the inductor.

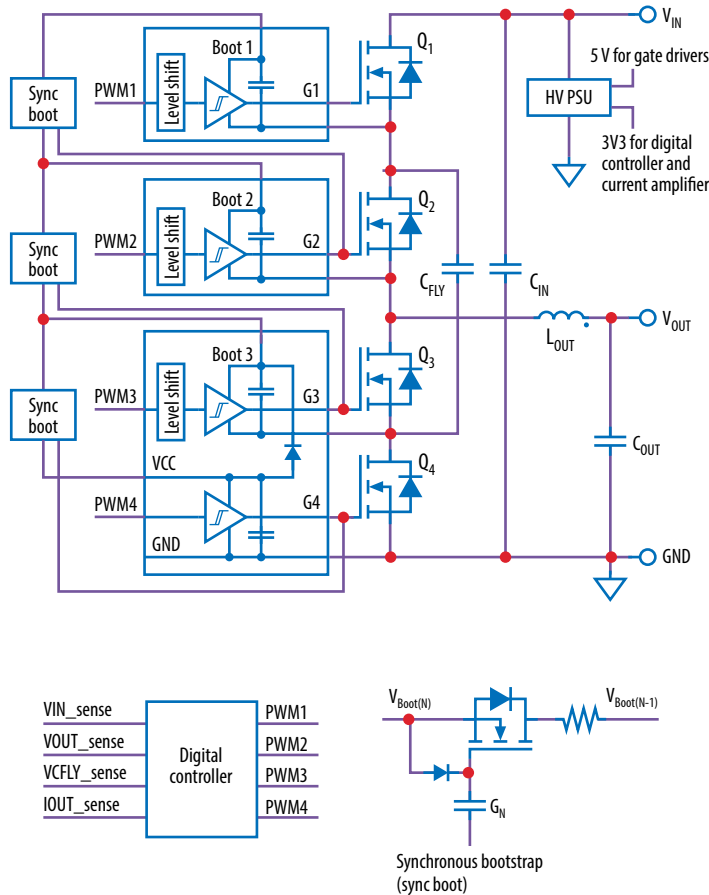
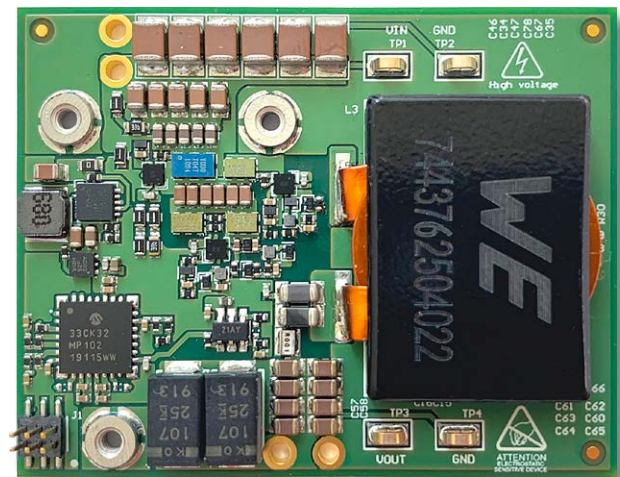

Figure 1: Block diagram of the EPC9148 demonstration board



Top view
EPC9148 development board

QUICK START PROCEDURE

Demonstration board EPC9148 measures 51 mm x 40 mm x 5 mm (total) and is easy to set up for evaluation. Refer to Figures 2-4 and follow the procedure below for proper connect and measurement setup:

1. With power off, connect the input power supply to V_{IN} and GND as shown in Figure 2 from top side or as in Figure 3 from bottom side.
2. With power off, connect the load to V_{OUT} and GND as in Figure 2 from top side or as in Figure 3 from bottom side.

3. Making sure the initial input supply voltage is 0 V, turn on the power and increase the voltage to the required value (do not exceed the absolute maximum voltage 60 V). Output voltage regulation begins at 44 V input voltage or lower for lower output voltage. Probe switching node to see switching operation as shown in Figure 4.
4. Once operational, adjust the load within the operating range and observe the output switching behavior, efficiency and other parameters as in Figure 4.
5. For shutdown, please follow the above steps in reverse.

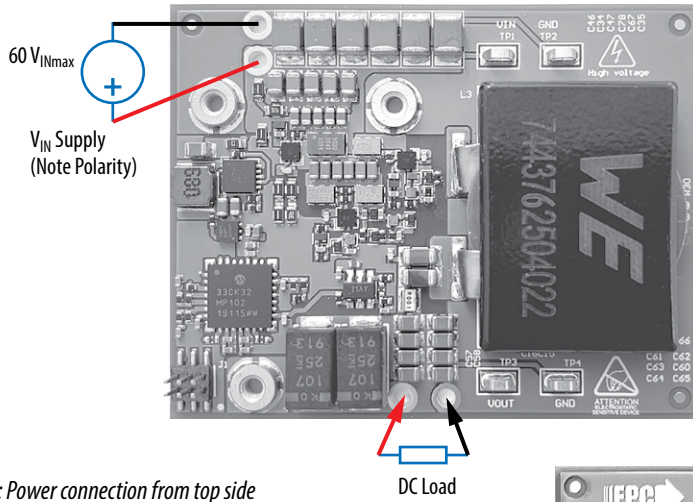

Figure 2: Power connection from top side

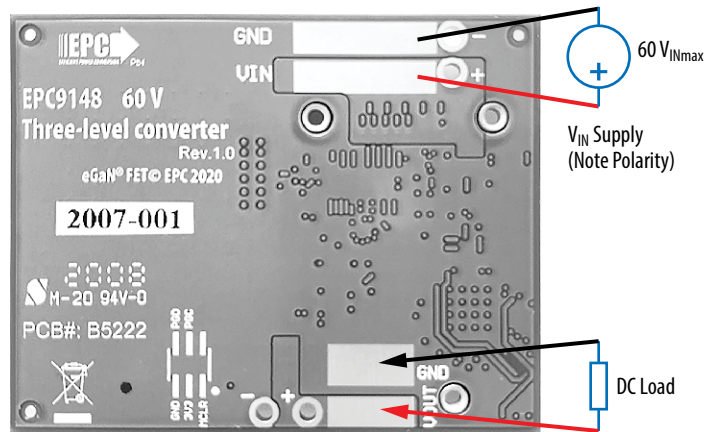

Figure 3: Power connection from bottom side

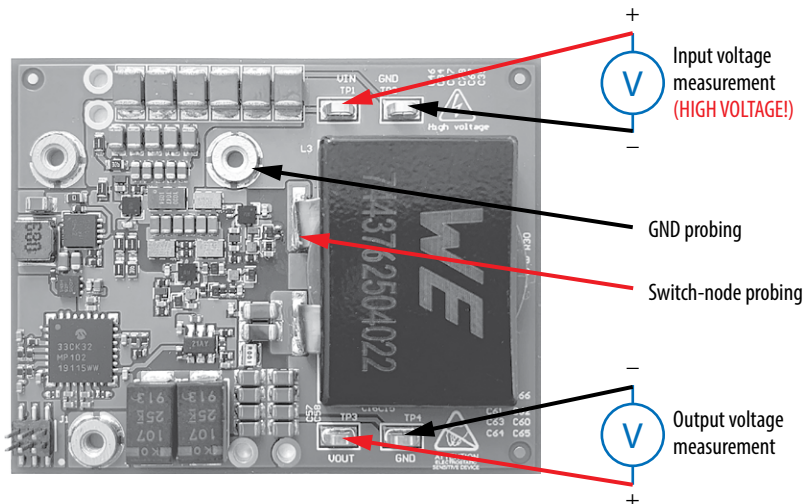

Figure 4: Measurement connection

CONTROLLER

The EPC9148 features a Microchip dsPIC33CK32MP102 Digital Signal Controller (DSC). This 100 MHz single core device is equipped with dedicated peripheral modules for Switched-Mode Power Supply (SMPS) applications, such as a feature-rich 4-channel (8x output), 250 ps resolution pulse-width modulation (PWM) logic, three 3.5 Msps Analog-To-Digital Converters (ADC), three 15 ns propagation delay analog comparators with integrated Digital-To-Analog Converters (DAC) supporting ramp signal generation, three operational amplifiers as well as Digital Signal Processing (DSP) core with tightly coupled data paths for high-performance real-time control applications.

The dsPIC33CK device is used to drive and control the converter in a fully digital fashion where the feedback loops are implemented and executed in software. There are three software control loops: a) average current loop; b) output voltage loop and c) flying capacitor voltage loop.

Average current mode control (ACMC) is implemented for output voltage regulation. The converter is controlled by the outer voltage loop providing a reference to the inner average current loop as shown in figure 6. The inner current loop is adjusted to average cross-over frequencies of 8 kHz. To balance the current reference perturbation of the inner current loop, the outer voltage loop has been adjusted to an average cross-over frequency of 2 kHz, which determines the overall response time of the converter.

Flying capacitor voltage is regulated to 1/2 Vin using another independent control loop and the loop cross-over frequency is set to 1 kHz as shown in figure 7.

THERMAL CONSIDERATIONS

The EPC9148 is intended for bench evaluation with low ambient temperature and convection cooling. The addition of heatsinking and forced air cooling can significantly increase the current rating of these devices, but care must be taken to not exceed the absolute maximum die temperature of 150°C. The EPC9148 board is designed with three threading mounting posts that can be use to easily attach a heat-spreader/heatsink as shown in Figure 8. It only requires a thermal interface material (TIM), a custom shape heat-spreader/heatsink, a thin insulation layer for the components with exposed conductors such as capacitors and resistors and screws. For more information about how to attach a heatsink, the EPC website offers: ["AN012 How to Get More Power Out of a High-Density eGaN®-Based Converter with a Heatsink."](#)

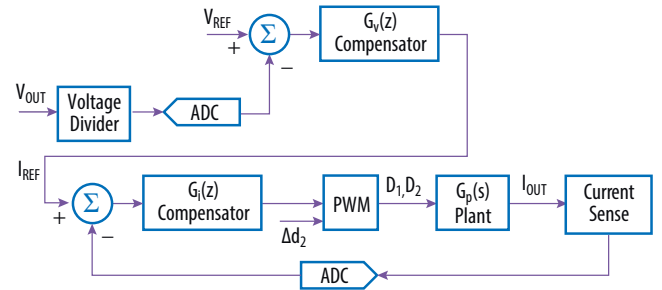

Figure 6. Block diagram of the average current mode controller (ACMC) with flying capacitor voltage adjust duty cycle control input.

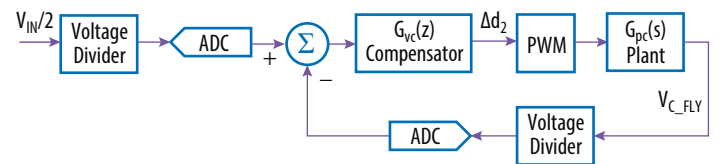

Figure 7. Block diagram of the flying capacitor voltage controller with duty cycle adjust output.

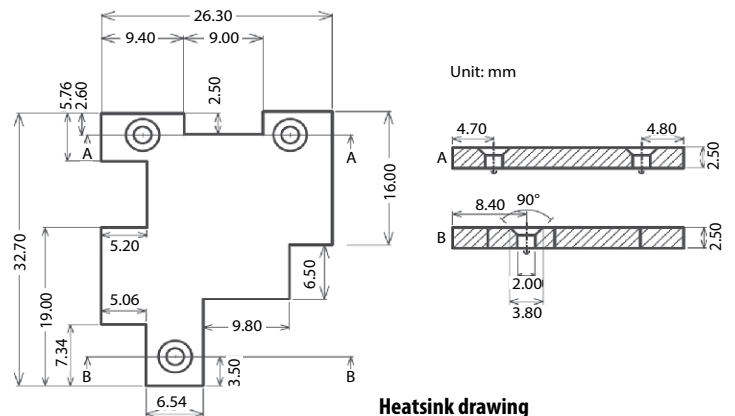
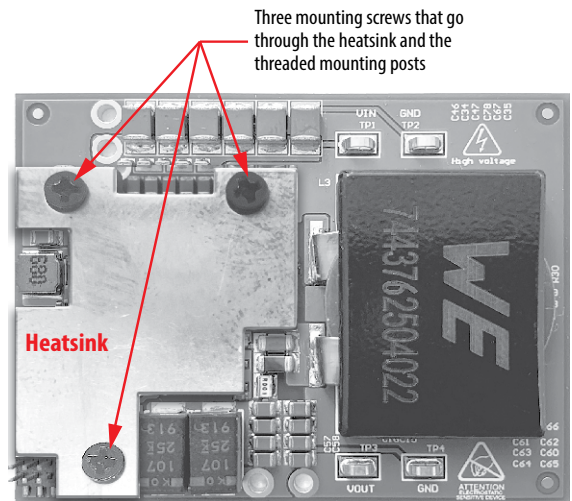

Figure 8: Heatsink attachment

MEASUREMENT CONSIDERATIONS

When measuring the switch-node waveform with high-frequency content, care must be taken to provide a high-fidelity measurement. It is recommended to avoid long ground connection and minimize the measurement loop.

NOTE: The switch-node probing indicated are just for sanity check, and may not be optimal for observing the switching transients. For accurate transient measurement, please use [EPC9093](#), the development board for [EPC2053](#). For information about measurement techniques, the EPC website offers: “[AN023 Accurately Measuring High Speed GaN Transistors](#)” and the How to GaN educational video series, including: [HTG09 Design Basics - Measurement](#).

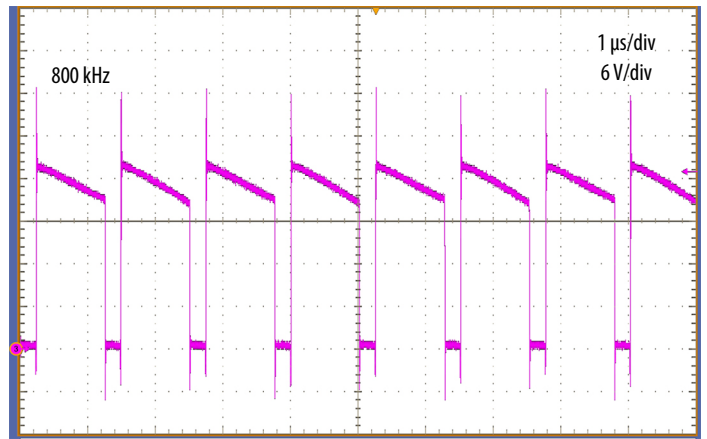

Figure 9: Switch-node waveform at 48 V input to 19 V, 12.5 A output

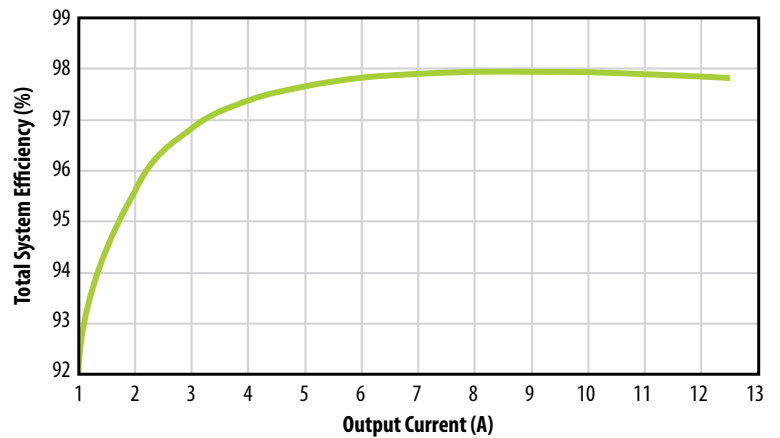

Figure 10: Total system efficiency as a function of the output current at 48 V input to 19 V output

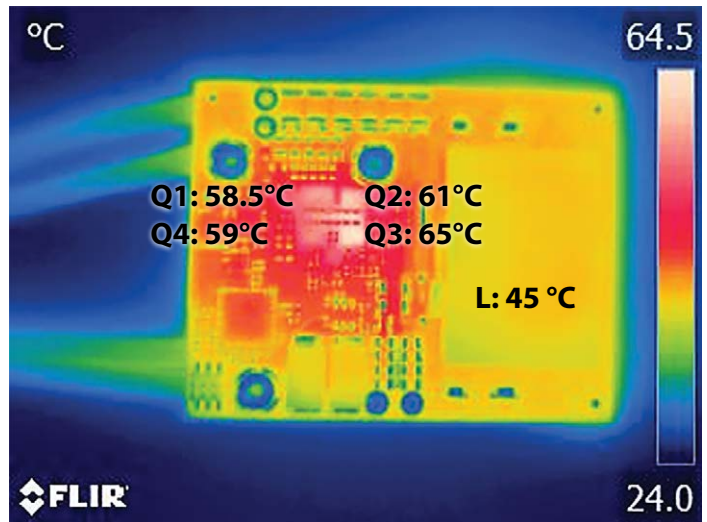

Figure 11: Thermal image of the EPC9148 at 48 V input to 19 V, 12.5 A output with 800 LFM forced air

DEVELOP YOUR OWN CONTROL PROGRAM

The EPC9148 board can be programmed through the programming header J1 and used to develop control for the three-level converter. A ribbon cable such as FFSD-04-D-06.00-01 is needed for connection to the programming kit. Development tools can be found at www.microchip.com/development-tools.

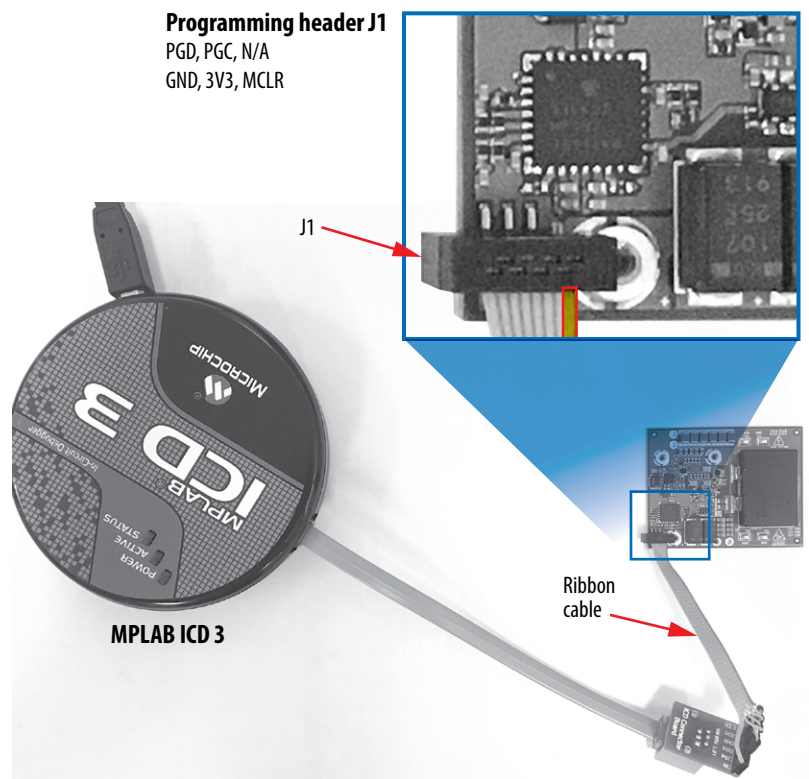

Figure 12: Programming connection

Table 2: Bill of Materials

Item	Qty	Reference	Part Description	Manufacturer	Part Number
1	8	C1, C3, C4, C5, C6, C15, C17, C77	10 nF ±10% 50 V Ceramic Capacitor X7R 0402	Würth	885012205067
2	1	C2	51 pF ±5% 50 V Ceramic Capacitor NP0 0402	Samsung	CL05C510JB5NNNC
3	6	C7, C13, C43, C44, C45, C69	1 µF ±20% 100 V Ceramic Capacitor X7S 0805	TDK	C2012X7S2A105M125AE
4	9	C8, C14, C16, C22, C25, C68, C70, C71, C72	0.1 µF ±10% 25 V Ceramic Capacitor X7R 0402	Yageo	CC0402KRX7R8BB104
5	1	C9	1 µF ±10% 25 V Ceramic Capacitor X7R 0603	Würth	885012206076
6	1	C10	10 µF ±10% 16 V Ceramic Capacitor X5R 0603	Murata	GRM188R61C106KAALD
7	4	C11, C24, C36, C55	1 µF ±20% 10 V Ceramic Capacitor X5R 0402	Würth	885012105012
8	1	C12	10 µF ±20% 10 V Ceramic Capacitor X5R 0402	Samsung	CL05A106MP8NUB8
9	3	C23, C26, C28	22 nF ±10% 25 V Ceramic Capacitor X7R 0402	Würth	885012205052
10	1	C27	0.22 µF ±10% 25 V Ceramic Capacitor X7R 0402	TDK	CGA2B3X7R1E224K050BB
11	6	C34, C35, C46, C47, C67, C78	4.7 µF ±10% 100 V Ceramic Capacitor X7S 1210	TDK	CGA6M3X7S2A475K200AB
12	5	C39, C40, C41, C42, C73	0.22 µF ±10% 100 V Ceramic Capacitor X7S 0603	Taiyo Yuden	HMK107C7224KAHTE
13	6	C48, C49, C50, C51, C52, C53	2.2 µF ±10% 50 V Ceramic Capacitor X5R 0603	Murata	GRM188R61H225KE11D
14	1	C54	33 pF ±5% 50 V Ceramic Capacitor NP0 0402	Würth	885012005058
15	2	C57, C58	100 µF 25 V Tantalum Polymer Capacitor 2917	Kemet	T521X107M025ATE03
16	8	C59, C60, C61, C62, C63, C64, C65, C66	22 µF ±20% 25 V Ceramic Capacitor X5R 0805	TDK	C2012X5R1E226M125AC
17	1	C76	2.2 µF ±20% 25 V Ceramic Capacitor X5R 0402	TDK	C1005X5R1E225M050BC
18	6	D1, D2, D3, D6, D8, D10	Diode Schottky 40 V 200 mA (DC)	Diodes	BAS40LP-7
19	3	D5, D7, D9	Zener Diode 5.1 V 250 mW ±6%	Diodes	BZT52C5 V1LP-7
20	1	J1	Connector Header Surface Mount 6 position 0.050	Würth	62130621021
21	1	L1	68 µH Shielded Wirewound Inductor 540 mA 840 mΩ	Würth	74404042680
22	1	L3	2.4 µH Ferrite Inductor 15 A 1mΩ	Würth	7443762504022
23	1	Q1	N-Channel 100 V 3.8 mΩ GaN FET	EPC	EPC2053
24	3	Q2, Q3, Q4	N-Channel 40 V 3.5 mΩ GaN FET	EPC	EPC2055
25	3	Q8, Q9, Q10	100 V Internal Gate Diode 3300 mΩ GaN FET	EPC	EPC2038
26	1	R1	15 kΩ ±0.1% 0.063 W, 1/16 W Chip Resistor 0402	Panasonic	ERA-2AEB153X
27	1	R2	2 kΩ ±0.1% 0.063 W, 1/16 W Chip Resistor 0402	Yageo	RT0402BRD072KL
28	3	R3, R4, R5	39 kΩ ±0.1% 0.2 W, 1/5 W Chip Resistor 0603	Panasonic	ERJ-PB3B3902V
29	2	R6, R8	2 kΩ ±0.1% 0.1 W, 1/10 W Chip Resistor 0603	Panasonic	ERA-3AEB202V
30	1	R7	2.2 kΩ ±0.1% 0.2 W, 1/5 W Chip Resistor 0603	Panasonic	ERJ-PB3B2201 V
31	1	R9	0 Ω Jumper 0.1 W, 1/10 W Chip Resistor 0603	Panasonic	ERJ-3GEY0R00V
32	4	R10, R11, R12, R14	15 kΩ ±0.5% 0.063 W, 1/16 W Chip Resistor 0402	Yageo	RT0402DRE0715KL
33	1	R13	1 kΩ ±5% 0.063 W, 1/16 W Chip Resistor 0402	Yageo	RC0402JR-071KL
34	1	R15	36 kΩ ±0.1% 0.2 W, 1/5 W Chip Resistor 0603	Panasonic	ERJ-PB3B3602V
35	1	R16	100 kΩ ±1% 0.063 W, 1/16 W Chip Resistor 0402	Yageo	RT0402FRE07100KL
36	1	R17	20 Ω ±1% 0.1 W, 1/10 W Chip Resistor 0402	Panasonic	ERJ-2RKF20R0X
37	1	R18	31.6 kΩ ±1% 0.063 W, 1/16 W Chip Resistor 0402	Panasonic	RC0402FR-0731K6L
38	1	R23	10 kΩ ±5% 0.063 W, 1/16 W Chip Resistor 0402	Yageo	RC0402JR-0710KL
39	4	R25, R54, R47, R48	0 Ω Jumper 0.1 W, 1/10 W Chip Resistor 0402	Panasonic	ERJ-2GE0R00X
40	7	R27, R28, R31, R32, R38, R39, R40	1 Ω ±1% 0.063 W, 1/16 W Chip Resistor 0402	Yageo	RC0402FR-071RL
41	3	R29, R33, R41	27 kΩ ±5% 0.1 W, 1/10 W Chip Resistor 0402	Panasonic	ERJ-2GEJ273X
42	3	R30, R37, R42	4.7 Ω ±1% 0.063 W, 1/16 W Chip Resistor 0402	Stackpole	RMCF0402FT4R70
43	2	R44, R45	50 Ω @ 100 MHz Ferrite Bead 1206 12A 1.6mΩ	Murata	BLM31SN500SH1L
44	1	R46	1 mΩ ±5% 1 W Chip Resistor Wide 0805	Susumu	KRL2012E-M-R001-J-T5
45	3	S2, S3, S5	Round Standoff Threaded M2x0.4 Steel 0.039	Würth	9774010243R
46	4	TP1, TP2, TP3, TP4	PC Test Point	Keystone	5015
47	1	U1	Current Sense Amplifier 1 Circuit SOT-23-6	Microchip	MCP6C02T-100E/CHY
48	1	U2	dsPIC dsPIC™ 33CK Microcontroller IC 16-Bit 100 mHz 32KB (32K x 8) FLASH 28-UQFN (6x6)	Microchip	DSPIC33CK32MP102-I/2N
49	1	U4	Buck Switching Regulator IC Output 150 mA 10-VDFN Exposed Pad	Texas Instruments	LM5165DRCR
50	1	U5	Linear Voltage Regulator IC 500 mA 6-WSON	Texas Instruments	TLV75533PDRVR
51	3	U9, U10, U11	Dual-Channel Gate Driver for GaN FETs	uPI	uPI966A

Optional Components

Item	Qty	Reference	Part Description	Manufacturer	Part Number
1	1	C56	33 pF \pm 5% 50 V Ceramic Capacitor NP0 0402	Würth	885012005058
2	3	N/A	Black-Oxide 18-8 Stainless Steel Phillips Flat Head Screws, M2 x 0.4 mm Thread, 5 mm	McMaster-Carr	91698A201
3	1	N/A	Ribbon Cable	Samtec	FFSD-04-D-06.00-01
4	1	N/A	Thermal Pad	t-global	TGX

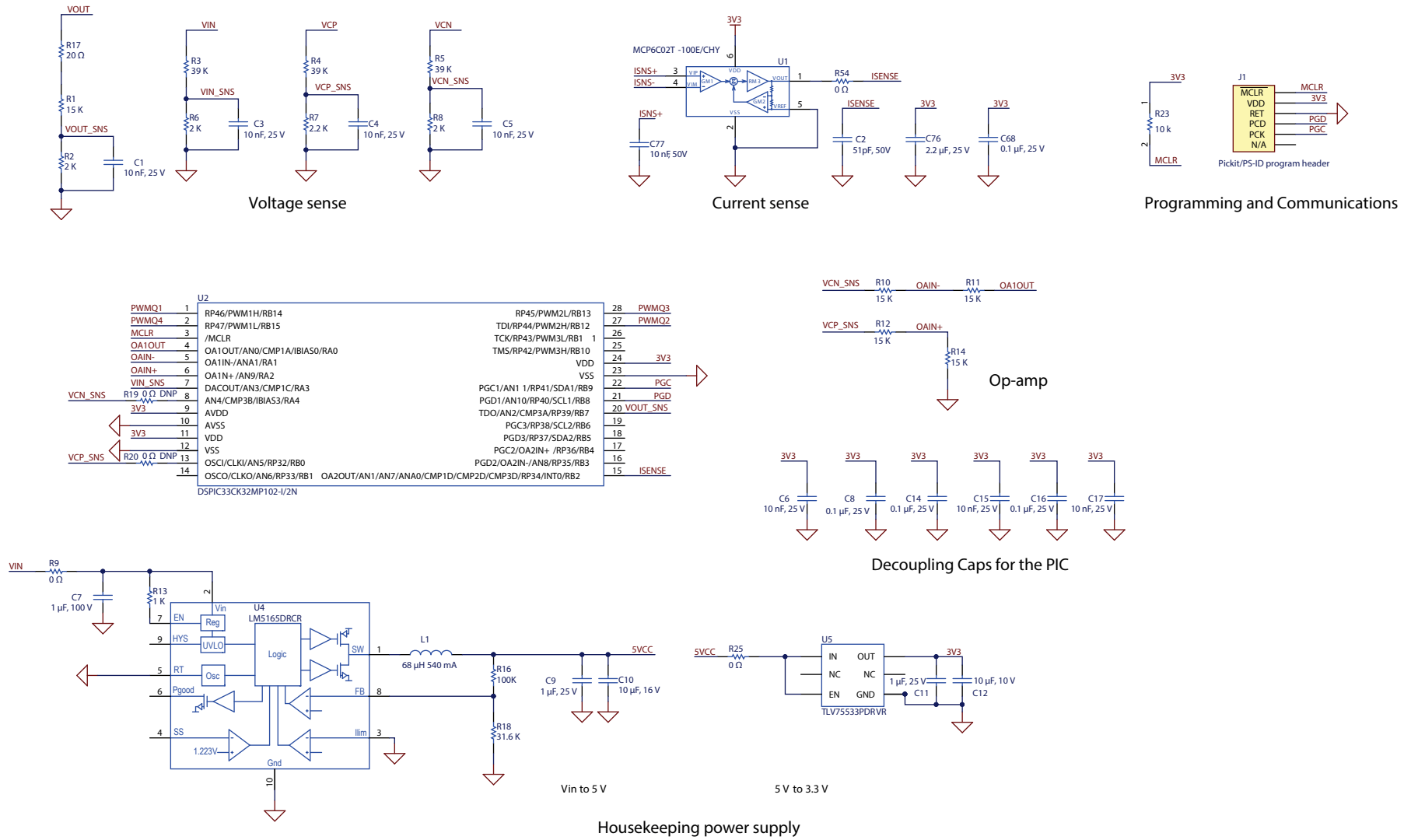
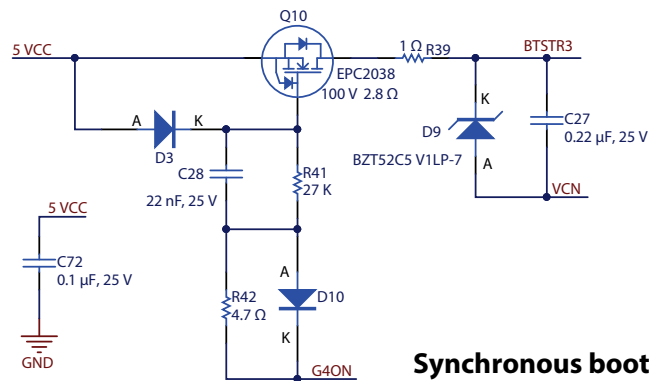
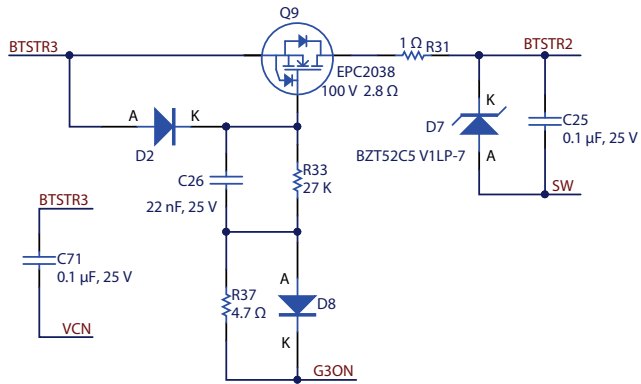
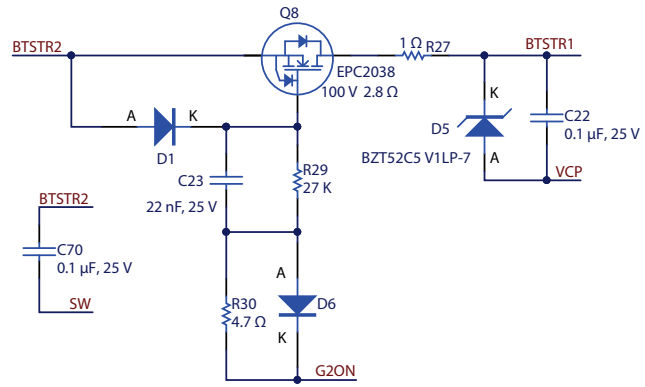
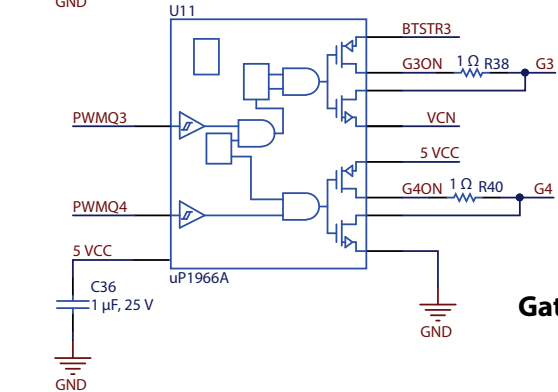
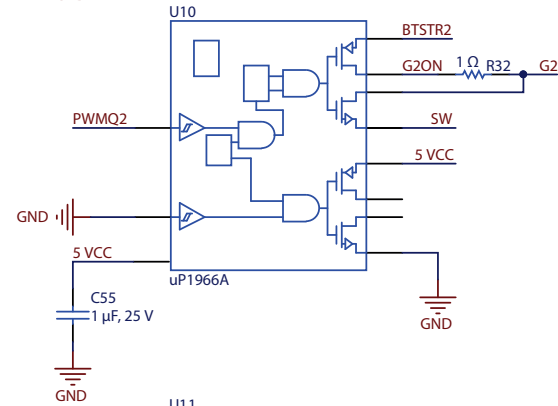
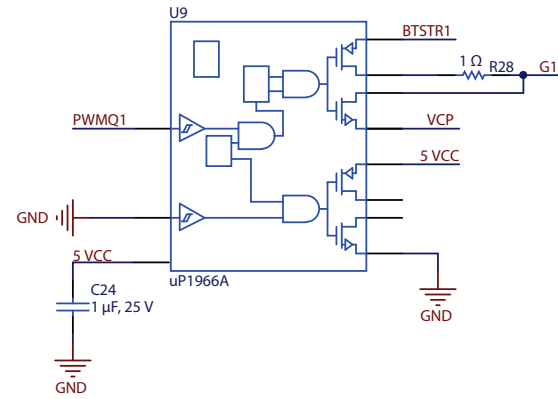

Figure 13: EPC9148 housekeeping power supply and controller schematic (1 of 3)



Synchronous bootstrap



Gate driver circuit

Figure 14: EPC9148 gate driver schematic (2 of 3)

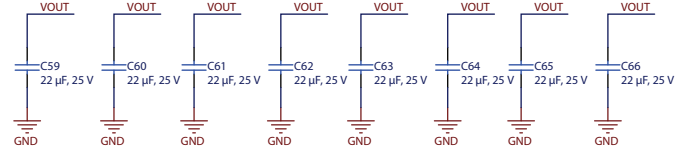
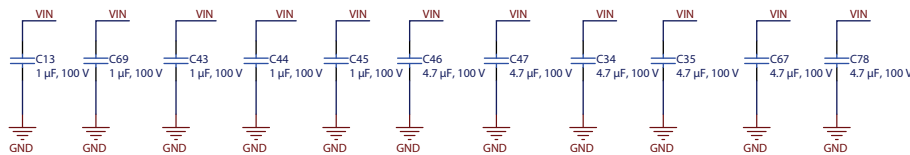
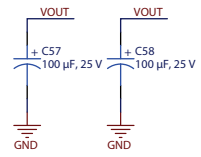
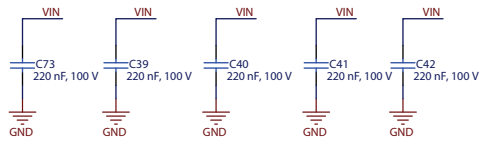

Input capacitors

Output capacitors

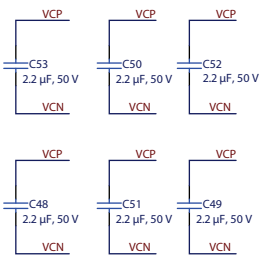

Flying capacitors

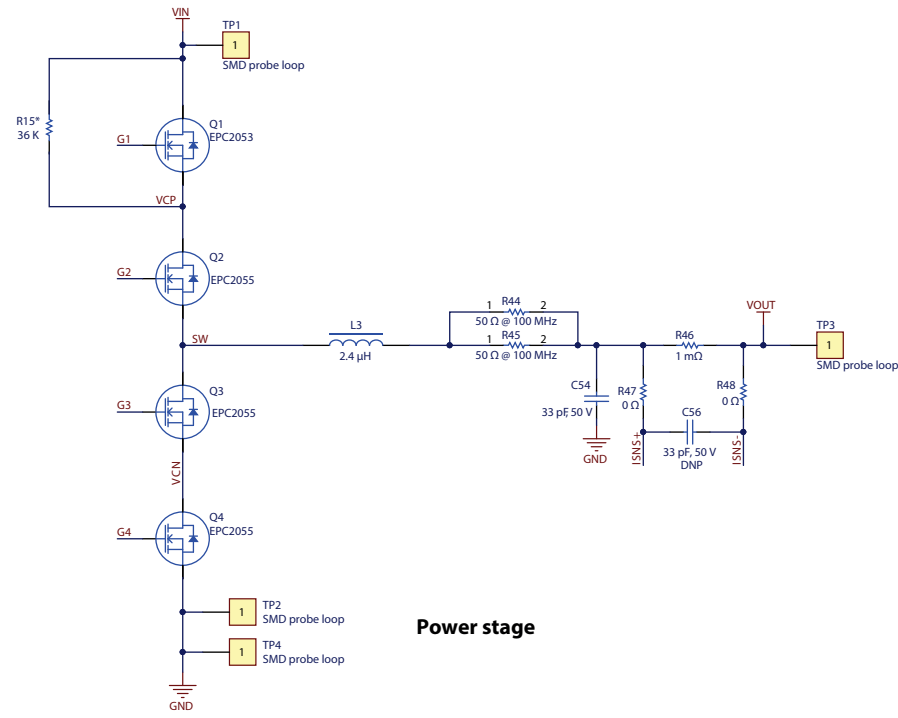

Power stage

* Start-up patent pending

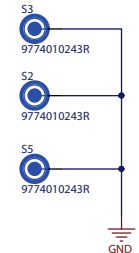

Heatspreader Standoffs

FD1 FD2 FD3
PCB Fiducial



Figure 15: EPC9148 power stage schematic (3 of 3)



EPC would like to acknowledge Microchip Technology Inc. (www.microchip.com) for their support of this project.

Microchip Technology Incorporated is a leading provider of smart, connected and secure embedded control solutions. Its easy-to-use development tools and comprehensive product portfolio enable customers to create optimal designs, which reduce risk while lowering total system cost and time to market. The company's solutions serve customers across the industrial, automotive, consumer, aerospace and defense, communications and computing markets.

The EPC9148 system features the **dsPIC33CK32MP102** 16-Bit Digital Signal Controller with High-Speed ADC, Op Amps, Comparators and High-Resolution PWM. Learn more at www.microchip.com.



EPC would like to acknowledge Würth Elektronik (www.we-online.com) for their support of this project.

Würth Elektronik is a premier manufacturer of electronic and electromechanical passive components. EPC has partnered up with WE for a variety of passive component requirements due to the performance, quality and range of products available. The EPC9148 development board features various WE product lines including power inductors, capacitors, and connectors.

One of the highlights on the board is a custom super-thin power inductor which helps to enable the power density of this design. Also featured on the board are the WE-LQS SMT power inductors, the WCAP-CSGP MLCC capacitors, and WR-PHD 1.27 mm SMT Dual Pin Header connectors. Learn more at www.we-online.com.

For More Information:

Please contact info@epc-co.com
or your local sales representative

Visit our website:
epc-co.com

Sign-up to receive
EPC updates at
bit.ly/EPCupdates
or text "EPC" to 22828



EPC Products are distributed through Digi-Key.
www.digikey.com

Demonstration Board Notification

The EPC9148 board is intended for product evaluation purposes only. It is not intended for commercial use nor is it FCC approved for resale. Replace components on the Evaluation Board only with those parts shown on the parts list (or Bill of Materials) in the Quick Start Guide. Contact an authorized EPC representative with any questions. This board is intended to be used by certified professionals, in a lab environment, following proper safety procedures. Use at your own risk.

As an evaluation tool, this board is not designed for compliance with the European Union directive on electromagnetic compatibility or any other such directives or regulations. As board builds are at times subject to product availability, it is possible that boards may contain components or assembly materials that are not RoHS compliant. Efficient Power Conversion Corporation (EPC) makes no guarantee that the purchased board is 100% RoHS compliant.

The Evaluation board (or kit) is for demonstration purposes only and neither the Board nor this Quick Start Guide constitute a sales contract or create any kind of warranty, whether express or implied, as to the applications or products involved.

Disclaimer: EPC reserves the right at any time, without notice, to make changes to any products described herein to improve reliability, function, or design. EPC does not assume any liability arising out of the application or use of any product or circuit described herein; neither does it convey any license under its patent rights, or other intellectual property whatsoever, nor the rights of others.